

A GUIDE TO CONNECTORS

A LOOK AT THE MAJOR FEATURES OF AN ELECTRICAL CONNECTOR

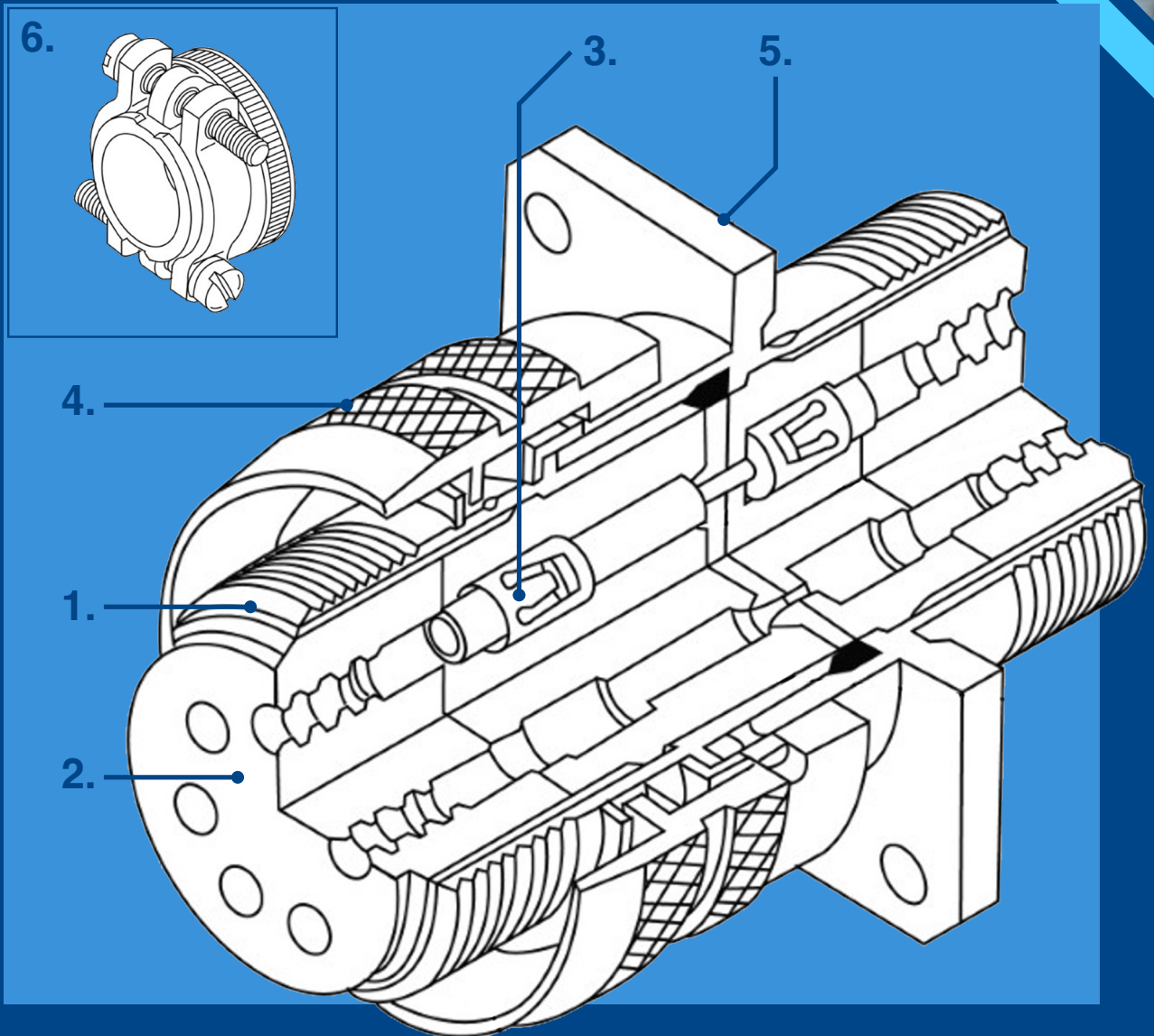

A MATING PAIR OF CIRCULAR CONNECTORS NORMALLY CONSISTS OF A PLUG AND RECEPTACLE CONNECTOR:

1. OUTER SHELL

The shell forms the outer cover that adds strength and houses the other components. This is usually made from polycarbonate plastic, stainless steel, aluminium, or a composite material. This will typically have an additional outer plating to improve conductivity and provide additional corrosion resistance.

2. INSERT

As well as structurally holding the contacts, the insert provides insulation that allows electricity to flow from the wire through the contacts without short circuiting. Commonly made from a synthetic polymer/ rubber.

3. CONTACTS

A pair of connectors will have a pin contact in one half and a socket contact in the mating half. The contacts are used to transmit electrical power, signals, or RF through the connector. The contacts can have various designs, such as crimp or solder to allow connection to an electrical wire or can have a PC tail to allow direct connection to a printed circuit board (PCB).

4. COUPLING

Circular connectors normally have a coupling nut fitted to the plug, this is used to secure the plug onto the mating receptacle and uses a thread or bayonet system to give a secure connection.

5. MOUNTING FLANGE

A mounting flange is used in applications that require the connector to be secured to a panel or box, and is typically on the receptacle half.

6. BACKSHELL

A backshell attaches to the rear of the connector. Various designs are available, offering the ability to hold the cable in place, provide environmental sealing, and shielding against electromagnetic interference (EMI).